

# MAC-XP Personnel Carrier



- MSHA Approved
- Three person capacity
- Soft Ride five point rubber mounted front suspension with Air-Ride.
- Double reduction rear drive axle with enclosed wet disc brakes
- Motor mounted park brake
- Heavy duty rear springs
- 600 amp programmable controller
- Re-regenerative braking
- 10 HP motor
- 45/9 or 55/9 -72 volt Industrial batteries in removable battery tray
- Control box designed with all operational controls built in
- Ergonomically fitted to driver

Damascus...Meeting and Exceeding your expectations with pride since 1980

**DAMASCUS**  
*Corporation*

Phone: 276-676-2376 or 800-390-7636

Mailing Address:

PO Box 610

Abingdon, VA 24212

<http://www.damascuscorp.com>

Fax: 276-676-0300

Shipping Address:

26864 Watauga Road

Abingdon, VA 24211

e-mail: [damascus@naxs.com](mailto:damascus@naxs.com)

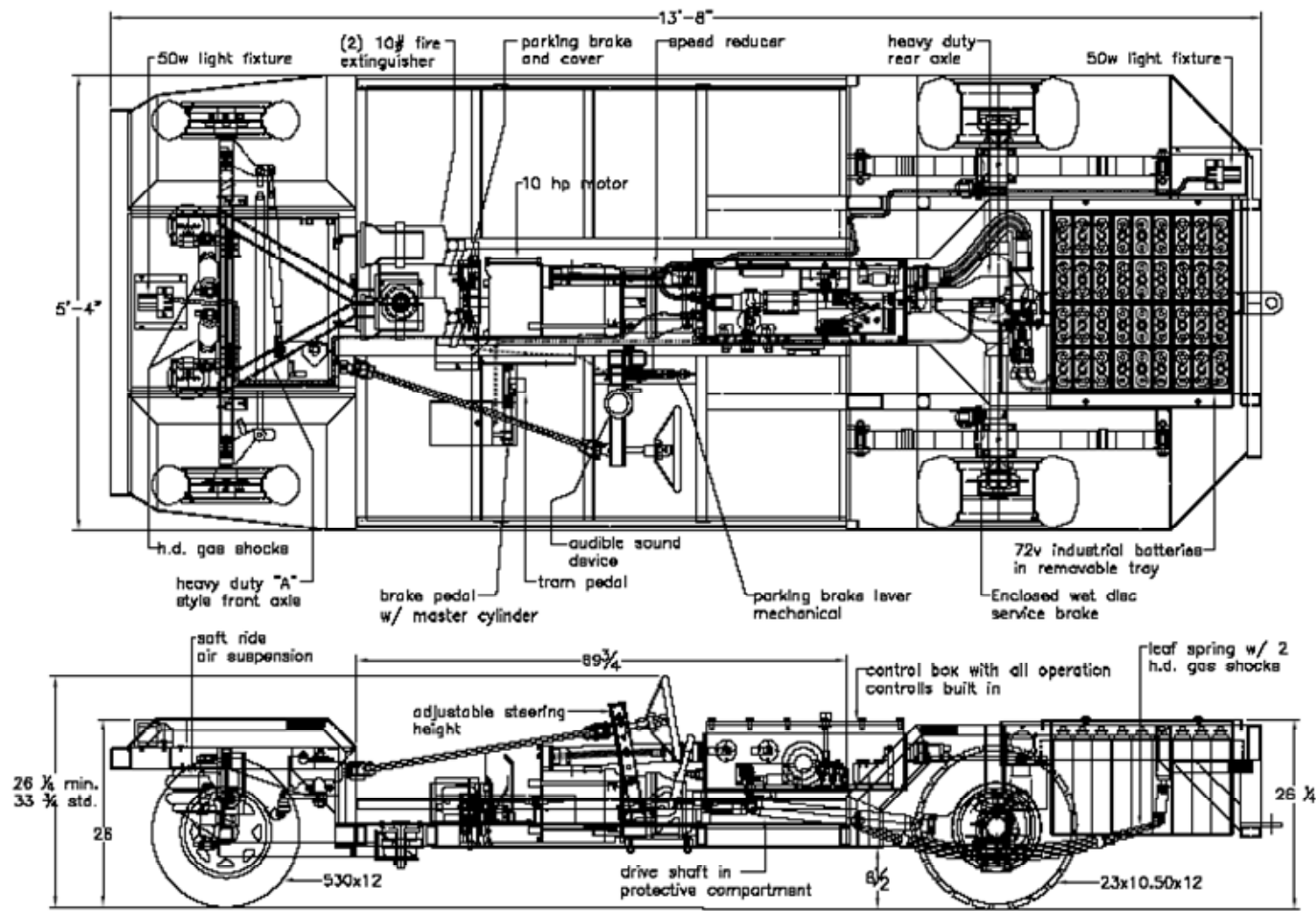

## Specifications: MAC-XP Personnel Carrier

Dimensions:	Height: 26 1/4 min. to top of steering wheel Width: 5'-4" Length: 13'-8" Turning Radius: 12'-0" I.S. Ground Clearance: 8 1/2" Standard	Motor:	Heavy duty double shaft, 10 HP
Payload:	1000 lb., 3 Men	Brake:	Service Brakes – Master cylinder actuated enclosed wet disc brakes in rear axle combined with regenerative braking Park Brake – mechanical caliper on motor shaft
Performance:	Speed 7 mph	Rear axle:	Double reduction 10,000# capacity axle with enclosed wet disc brakes
Electrical:	72 volt 600 amp Sevcon programmable controller, forward reverse contactors, circuit breaker, overload fuse, linear accelerator all located in an explosion proof enclosure	Suspension:	Front – Rubber mounted A frame style axle with new Soft Ride air suspension and heavy-duty gas shocks. Automotive type tie rods Rear – HD leaf springs with heavy duty gas shocks and rubber overload bumpers
Batteries:	Industrial type 36 cell 45/9 (OPT. 55/9) housed in removable tray	Fire Extinguisher:	Standard – (2) 10 lb. fire extinguisher and brackets
Speed Reducer:	High efficiency double reduction helical in line, 20 HP	Fire Suppression:	Optional - Ansul fire detection/suppression system
Battery Charger:	Heavy duty industrial Lester Electrical, automatic timer, Input: 220 volt Output: 72 volt – 40 amp	Tires:	Front: 530 x 12 – 6 ply rating Rear: 23 x 1050 x 12 - 6 Ply tractor tread standard
Headlights:	One front, one back, high intensity halogen	Options:	Seating, tires, canopy, ground clearance, and fire suppression. Contact Mfg. for more...