

# MAC-8WD+36 Electric Transporter



Soft Ride  
Suspension!

- Solid state 400 amp, Controller with bypass
- 48 volt T145 batteries in removable battery pack
- Soft Ride five point rubber mounted front suspension with Air-Ride.
- Up to thirteen passenger capacity.
- Automotive type rear axle.
- Speed: 7-9 MPH.
- Very low seam heights.
- Available in lay down or sit up driver position

**DAMASCUS**  
*Corporation*

*"We get around UNDERGROUND!!"*

Phone: 276-676-2376 or 800-390-7636

Mailing Address:

PO Box 610

Abingdon, VA 24212

<http://www.damascuscorp.com>

Fax: 276-676-0300

Shipping Address:

26864 Watauga Road

Abingdon, VA 24211

e-mail: [damascus@naxs.com](mailto:damascus@naxs.com)

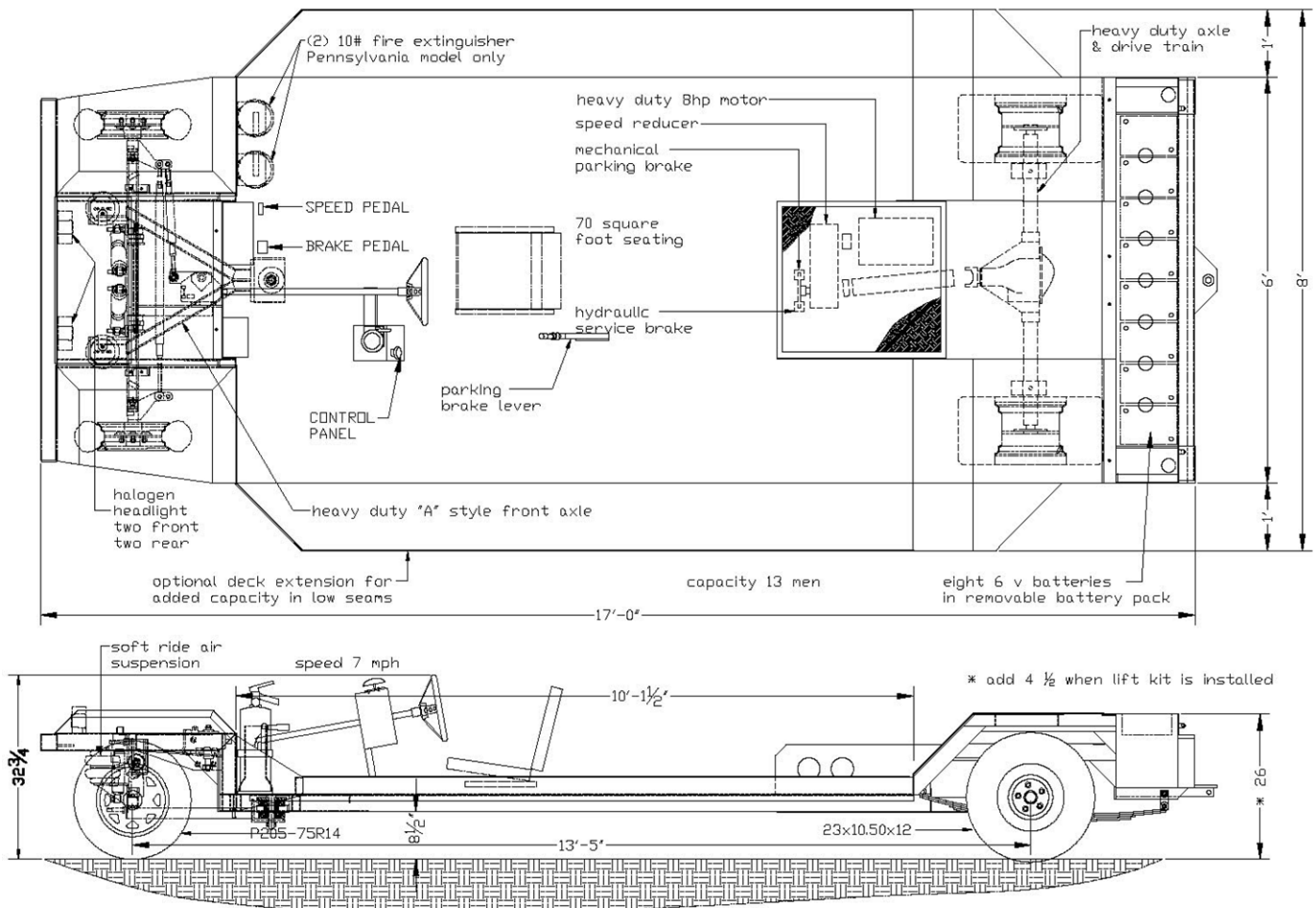

## **Specifications: MAC-8WD+36 Electric Transporter**

<p><b>Dimensions:</b> Height: 26" Standard 29" J305 Batteries Width: 6'-0" or 8'-0" Length: 17'-0" Turning Radius: 14'-0" I.S.</p>	<p><b>Headlights:</b> Two front, two rear, halogen, 48 volt no resistor required</p>
<p><b>Ground Clearance:</b> 8 1/2" Std. 13" with optional lift kit</p>	<p><b>Motor:</b> Heavy duty DC motor-continuous-TENV</p>
<p><b>Weight:</b> 2740#</p>	<p><b>Brake:</b> Hydraulic caliper service brake and mechanical parking brake both using a 10" rotor mounted on speed reducer output shaft</p>
<p><b>Payload:</b> 3000#, 13 men</p>	<p><b>Suspension:</b> Front – Rubber mounted A frame style axle with soft ride air suspension, heavy-duty gas shocks and overload bumpers Rear – HD leaf springs with heavy duty gas shocks and rubber overload bumpers</p>
<p><b>Electrical:</b> 48 volt MOSFET controller, forward/reverse/bypass contactors, circuit breaker with shunt trip encased in sealed enclosure</p>	<p><b>Front Axle:</b> A frame style with 3500# spindles, automotive king pins and tie rods</p>
<p><b>Batteries:</b> 8 – 6 volt Trojan T-145, battery level indicator on control panel. Removable battery pack</p>	<p><b>Rear Axle:</b> Automotive type 2700#</p>
<p><b>Speed Reducer:</b> Heavy duty parallel shaft</p>	<p><b>Tires:</b> Front: P205-75R14 – 6 ply rating Rear: 26 x 12.00 x 12 – 8 ply rating Other size available</p>
<p><b>Battery Charger:</b> Lester Electrical, Lestronic II, automatic timer. Input: 230 volt – 1 phase – 15 amp Output: 48 volt – 50 amp PA approved underground charger available</p>	<p><b>Tram Speed:</b> 7 miles per hour</p>