

# All New Multipurpose Vehicle



## MAC MV

**Ruggedness born from 30 years of manufacturing for the Appalachian coal mines, combined with the new age battery technology crafted the MAC MV – Multipurpose Vehicle**

Damascus Corporation, formerly known as the Damascus Pneumatics Corporation, was founded in Damascus, Virginia in 1980. In 1984, the need for personal transport vehicles, that were durable, economical and extremely functional for mine operations arose. Damascus responded and now constructs and assembles over 15 multi-sized, mining, personal transport, and multipurpose vehicles including a diesel line, and electric operated.

### The New MAC- MV MULTI-PURPOSE VEHICLE

- 100% battery powered utility and maintenance vehicle
- Durable 11 gauge steel frame manufactured in the USA
- Silent operations and zero emissions – ideal for indoor and outdoor operation
- Battery conveniently plugs into wall outlet
- 16-20 mile travel distance on single charge
- Operation equipment stays charged for 8 hour shift
- 5,000 lb heavy duty load capacity
- AC motor for less maintenance and higher performance rate

## DAMASCUS

*Corporation*

26864 Watauga Rd. Abingdon, VA 24211

office: 276.676.2376 • fax: 276.676.0300 • [www.Damascuscorp.com](http://www.Damascuscorp.com)

**Regional Sales: Jeff Brock 330.620.8549**

**[jbrock@damascuscorp.com](mailto:jbrock@damascuscorp.com)**

### Why Buy from Damascus?

1. Over 30 years of experience in design and manufacturing of underground equipment.
2. Quality crafted equipment, built to withstand the harsh underground environment
3. No nonsense Warranty
4. Large inventory of equipment and components are stocked at the factory to meet your needs
5. We service what we sell
6. Courteous, professional help with your needs, whether it be new equipment, components, field service, and technical telephone support
7. Damascus Corporation wants to hear your needs, providing solutions to effectively meet those needs is what we enjoy doing
8. Local distributors network, allows customer to deal with people they know and trust
9. Quality replacement components stocked by local distributor for same day service
10. **Damascus Corporation stands behind what they sell!!!**

## SPECIFICATIONS: MAC-MV Multipurpose Vehicle

Dimensions:	Height:	52"
	Width:	48"
	Length:	10' 4"
	Wheel Base:	4' 7"
	Ground Clearance:	6" to 12"
Weight:	approximately 2500 Lb (1134 Kg)	
Payload:	2 Person plus tools and equipment. 5000Lb (2268Kg)	
Electrical:	48 Volt AC Programmable Controller with onboard electronic dash display; No for/rev contactors; manual battery disconnect	
Batteries:	Battery Level Indicator on Control Panel Dash Display 8 - 6 Volt Batteries 145 Min. @ 75 Amps.	
Battery Charger:	Quick Charge on-board automatic charger; Constant voltage input: 115 volt-10amp; Output: 48 volt-18amp	
Headlights:	Two Front / One Rear, 48V	
Motor:	8HP, 3700W - High Torque, continuous duty AC motor with no brushes or commutator	
Brake:	Re-regenerative braking within electrical circuit, hydraulic disc/caliper rear brakes mounted on rear axle, manually activated parking brake	
Rear Axle:	5200 pound rear axle capacity with tapered roller bearings; Grease fittings at wheel bearings.	
Suspension:	Front – Triple acting front suspension with airbag adjustability and shocks Rear – Leaf spring mounted rear axle with shocks	
Tires:	23 x 8.50-12, 4ply Front and Rear	
Tram Speed:	Variable Speed	
Options	Canopy; Strobe light, tow hitch, bull bars, indicators, stake bed, tipping bed	

### GENERAL MACHINE LAYOUT

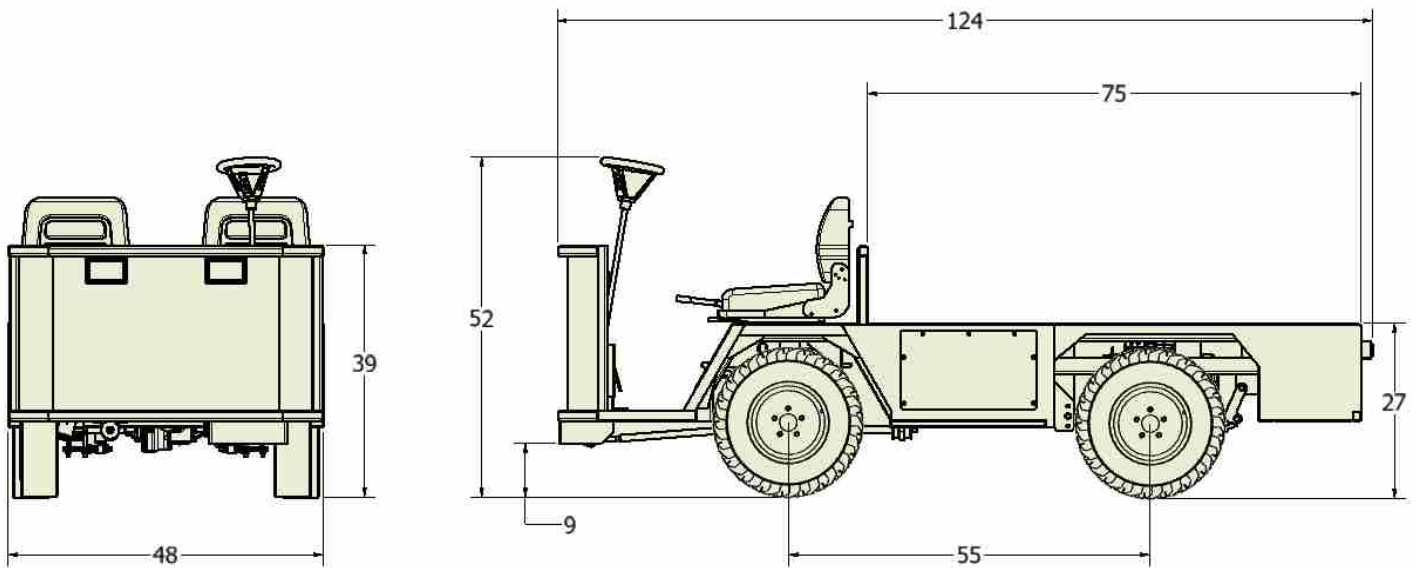

*"After using other types for a number of years and a thorough evaluation of a number of other utility vehicle options for our mall properties, the Damascus MAC-MV vehicle emerged as the clear leader in terms of value, considering both functionality and projected return on investment."*

**Gregory C. Link**  
**Senior Vice President – Management**  
**Premium Outlets® I SIMON®**